



celebrate, stimulate, communicate, brand, identify, talk, inspire

brand, talk, inspire, promote, stimulate, brand, excite, inform,

Payne Horseshoe Tab Cutter

Product Information

The Payne Horseshoe tab cutter consists of two main compartments.

- The Cutter Mechanism
- The Tab Save Device

CUTTER MECHANISM – The cutter mechanism is a compact unit designed to fit to most wrapping machines. It clamps and then cuts a horseshoe shaped tab 13mm wide x 20mm length or 9mm wide x 20mm length. It should be located a minimum of one pitch plus back from the main wrapper cut knife. Pneumatically operated and triggered via the wrapping machine whilst the film is in the stationary position. It is available in three throat sizes (100,150 and 200mm) to accommodate varying film widths.

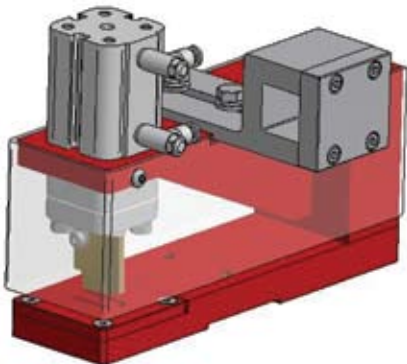

Payne Horseshoe Tab Cutter

TAB SAVE DEVICE – The tab save device is a compact, simple but clever mechanism which can be mechanically or pneumatically operated. It is designed to save the tab from being cut during the main film cut operation. The end result produces a tab on the pack that protrudes passed the seal area offering a highly visible opening feature to the consumer.

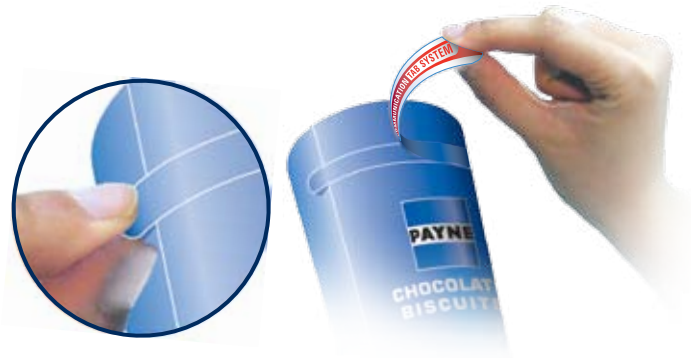

The highly visible tab coupled with a branding and communication tear tape offers a way of communicating with your customers to add value to your product.

TECHNICAL ADVICE AND SUPPORT - Payne specialists offer continuous advice and support, from initial consultation to installation operator training and beyond.

SPECIFICATION:	
Model:	HTC/12
Dimensions:	100 Throw 155(L) x 220(H) x 40(D)
	150 Throw 205(L) x 220(H) x 40(D)
	200 Throw 255(L) x 220(H) x 40(D)
Voltage:	24 VDC
Power:	6w
Air pressure:	6 bar, Clean and regulated
Weight:	3.0 kg